

Sludge Dewatering Unit - SDwU

Reduces your water in sludge by up to 85 %



Marinfloc SDwU 300/500

Oily sludge on board a ship is mainly produced by the refuse/reject from the Fuel Oil (FO) and Lub. Oil (LO) Purifiers and/or Automatic Back Flushing Filters. Some of the sludge does originate from leakage, which comes from cofferdams around FO settling and service tanks, pumps, filters, engines and boiler burners etc. This is led to the Sludge Oil Collecting Tank. Some ships do have separate Sludge Tanks for FO Sludge and LO Sludge. In any case, the sludge produced does not consist of 100% oil residues and solids. Water will be added when draining the FO settling(s) and service tanks, from sludge discharge from self cleaning centrifuges, from various steam and water leaks, when washing down and from condensation. As a matter of fact, the Oily Sludge in the Collecting tank can contain as much as 80 % of mixed free and bonded/homogenized water. For an incinerator to burn sludge oil with such a high water content is impossible without a supporting flame. To pump the sludge oil ashore costs a lot of money. Today often at a higher cost than for taking the FO bunker onboard. Thus we like to get out as much water as possible to either, make it possible to burn the Sludge Oil at its own calorific value, or/and to reduce the number of sludge discharges to shore collectors. The way to reduce the water in the Oily Sludge can be done in different ways : Manually, which will not reduce the water content enough or in using a centrifuge, which can give you a good result but at a high investment and maintenance costs. The third and a less expensive way to achieve a good sludge handling result is to invest in a Marinfloc SDwU installed (it) in a system as described on the back page of this flyer.

To be cont on page 2.3

Cont from page 1.3

Recommended Lay out of a Sludge De-watering System

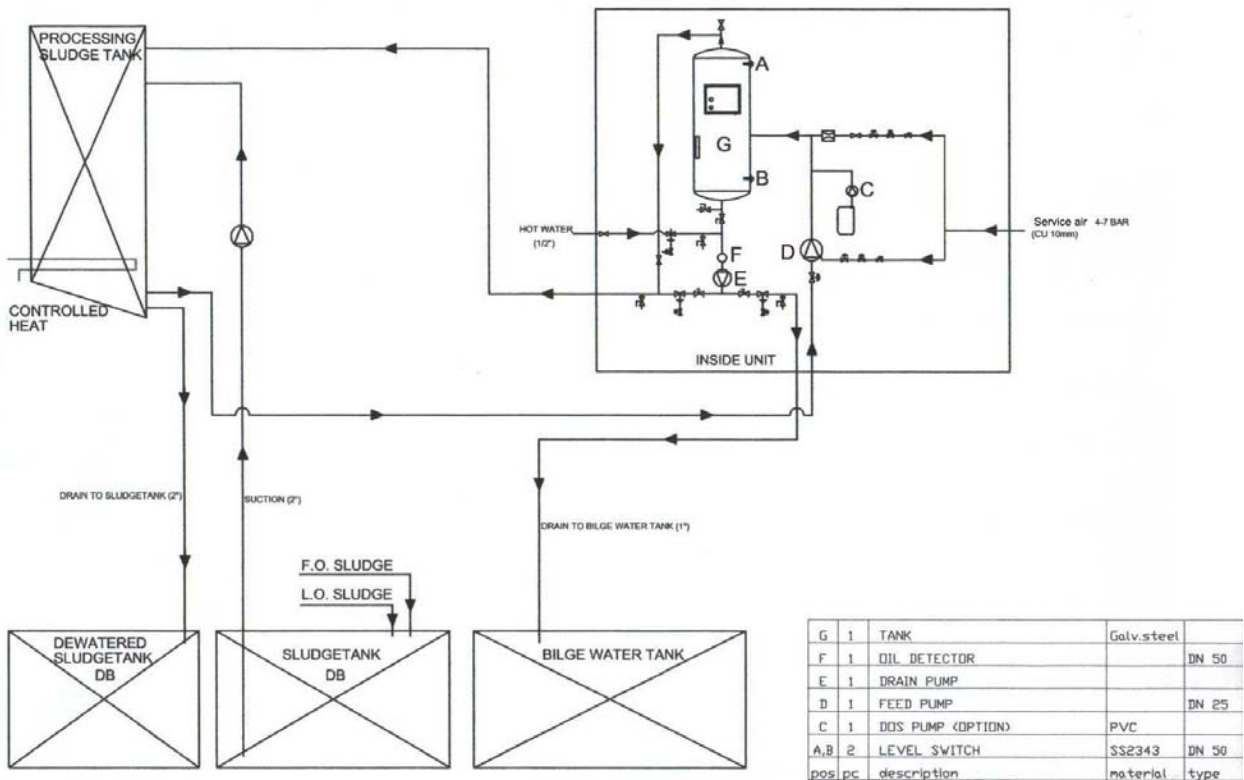

The SDwU can either be used in fully automatic - continuous operation or in a semi automatic mode, what ever preferred. The units only moving parts are the feed pump(D), the discharge pump (E) and a dosage pump (C) (Optional). The latter to be used in extreme conditions.

Brief description of the above system

In using the ships standard Sludge Transfer Pump, the sludge will be pumped from the Sludge DB Tank to the Sludge Process Tank. The Sludge is to be pre-heated in this tank to >+60 C but <+70 C° before it will be pumped by the SDwU feed pump (D) into the separation tank (G). During the filling sequence a small amount of compressed air will be fed into the system. To ensure that the tank (G) is completely filled, there will be a very short period of overfilling. The feed pump (D) stops. The separation sequence in the tank (G) will, after pump (E) stops, continue for a minimum of 15 minutes but a maximum 30 minutes. The lighter parts have now been, lifted to the top of the tank while the heavier parts have settled to the bottom. When the discharge pump (E) starts, the liquid will pass an oil-detector (F). If the monitor detects water a valve leading to the Bilge Water Holding Tank will open and if the monitor detects oil a valve leading to the Sludge Processing Tank will open. We do recommend to treat the volume of the, Process Tank at least three times, before draining the de-watered sludge to the “De watered Sludge Tank” or an “Incinerator Tank”

Why a Sludge Processing Tank

Sludge Tanks onboard ships are mainly DB tanks, which often means low and wide tanks with at least one part bordering to the sea. The suction pipe inlet is also often below the heating coils. In a tank of this shape to get an even temperature, and thus get a good settling at sea, is impossible. Further, there is always a constant influent of sludge and water to these tanks, i.e. Water is always being added. In a process tank, which either can be a free standing, superstructure or a split DB tank, you will have control of the sludge, which is to be de-watered. The volume of a process tank can vary from 1m³ up to 6 m³. The shape of the tank to be: L = variable x W = 1 x H = 2.

In using this type of tank you will have no influent of untreated sludge and water, you will need less heat energy, have a good control of the temperature and settling. Thus you will be able to have a good result when using any type of de watering equipment including a Marinfloc SDwU.

To be cont on page 3.3

Cont from page 2.3

Using two DB Sludge Tanks

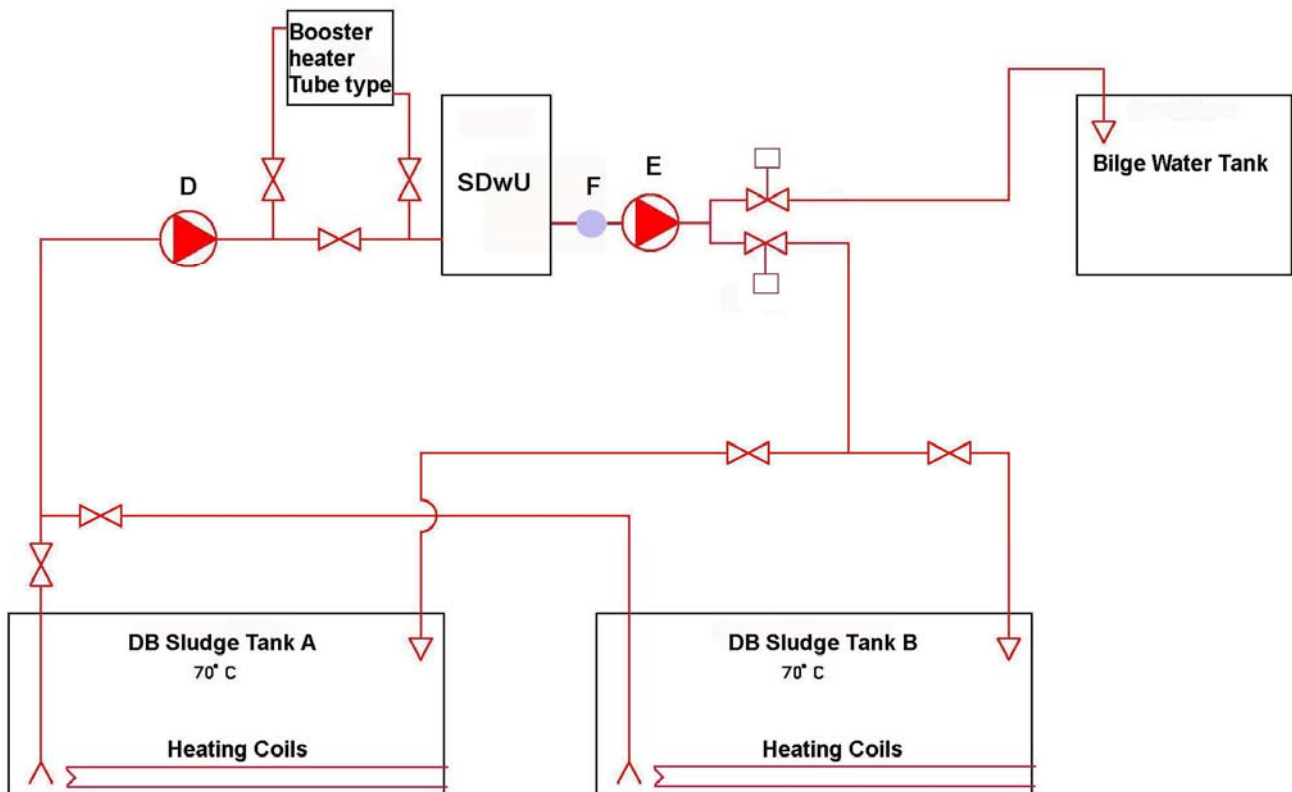

Brief description of the above system

As said on page 2.3, the Sludge Tanks onboard ships are mainly DB tanks, which often means low and wide tanks with at least one part bordering to the sea. The suction pipe inlet is also often below the heating coils. In a tank of this shape to get an even temperature, and thus get a good settling at sea, is very difficult close to impossible. However if it is impossible to accommodate a Sludge Processing Tank or/and the ship does not have an Incinerator Tank there is an optional possibility.

If the ship does have more than one DB Sludge Tank or if only Tank, divide this tank into two. Then, since there always is a flow of sludge and water to be collected and thus water always is being added to the sludge one of the tanks have to be "isolated". Thus if DB tank "A" is chosen to be a collecting tank (I.e. collecting drain from purifiers, back flushing filters etc) the other tank "B" shall have no other inlet connections than from the SDwU. In using this type of arrangement you will be able to "concentrate the sludge(De water) in tank "B".

If the system will be connected as shown below you will be able to run the system in two "modes"

"Filling " mode": Draw from "A" deliver to "B" and the "Bilge Water Tank"

"Round separation mode:": Draw from "B" deliver to "B" and the "Bilge Water Tank"

Even if the DB Sludge Tanks are equipped with heating coils but due to their lay out and shape the heating of the Sludge will very seldom be sufficient enough, why we do recommend to include a Booster Pre-heater of tube type.

Marinfloc AB

Head office and production
Industriavägen 10, SE-472 95 Varekil, Sweden
Tel.:+46 304 60 63 00, Fax:+46 304 100 51
e-mail: marinfloc@marinfloc.com
Web: www.marinfloc.com